



Quality products for life

Getting Started

Bonus Offer
Warranty Registration



UAM-820 Series



STEP 1

Device Setup

Insert 4 x AA batteries into bottom of the unit.
Plug arm cuff into the left side of the main unit.

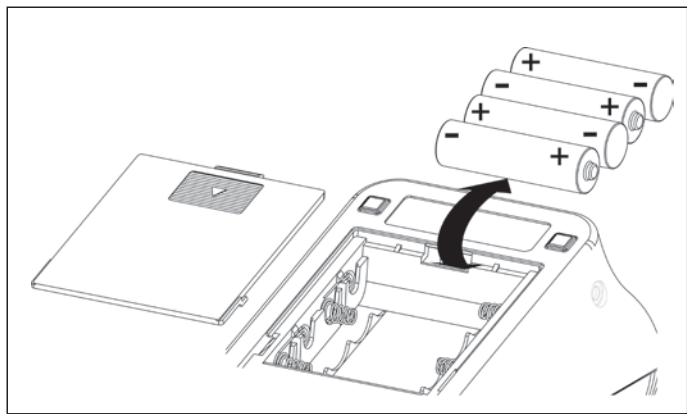

NOTE: To set up date and time, please refer to the instruction manual.

STEP 2

Confirm that the enclosed cuff is the correct size for your arm.

Use the enclosed tape measure to measure the circumference of your upper arm (measure biggest part), then

compare that measurement to the size imprinted on your cuff.

If your cuff is NOT the correct size, go to www.zewa.com/offer to order a different sized cuff (cuff is FREE, \$7.95 for shipping).

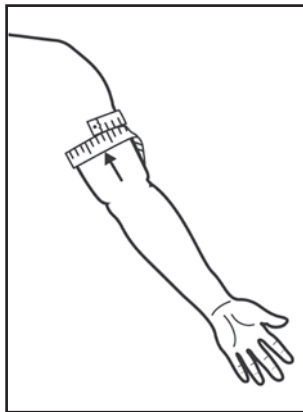

STEP 3

Place cuff directly on bare skin with cuff edge $\frac{1}{2}$ " above the elbow.

Tie the cuff around your upper arm with the tube centered, facing down towards your palm.

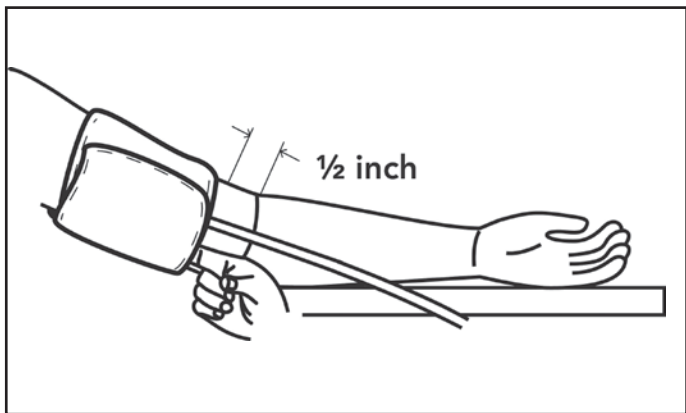

NOTE: Do NOT pull the end of the cuff out of the metal loop.

STEP 4

Correct position for an accurate measurement.

For accurate readings, sit upright in a chair with feet flat on the floor and arm resting on a flat surface in front of you so that the cuff is at the same level as your heart.

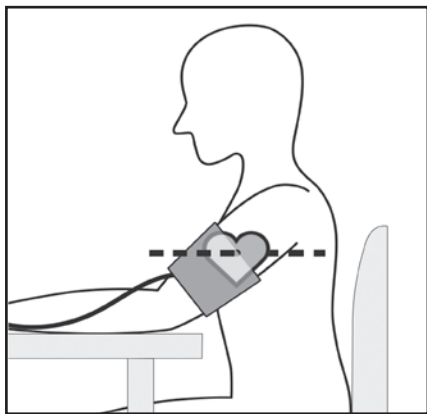

STEP 5

Rest for 5 minutes

Rest for 5 minutes before taking a measurement. Do not measure within 30 minutes after eating, exercising, bathing, smoking, drinking alcohol or waking up.



STEP 6

Taking a measurement.

When the monitor is OFF, press the START/STOP button to turn device ON and to start a measurement. Do not talk or move while taking a measurement.

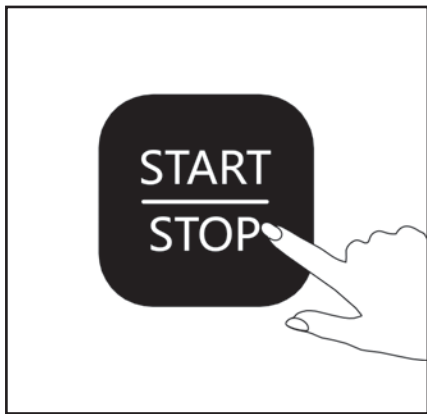

Frequently Asked Questions

Why does my blood pressure fluctuate throughout the day?

Your blood pressure changes constantly based on your daily activities and time of day. Because of this, some fluctuations can be expected.

Why do I get a different blood pressure reading at home compared to my doctor?

Having your blood pressure measured by a healthcare professional can cause nervousness and may result in an elevated reading.

Because these readings can vary considerably, you should take your blood pressure on a regular basis at home and share results with your healthcare provider.

My device does not turn ON or I am getting error messages.

Change the batteries (use a brand new set of batteries). If this does not resolve your issue, contact Zewa customer service at **1-888-993-3592** or at **www.zewa.com** (Contact us page).

Bonus Offer

Get 1 FREE cuff
or AC Adaptor

If the enclosed cuff is either too small or too large,
or if you want an extra cuff or AC Adaptor,
take advantage of this bonus offer.
Shipping and Handling not included (\$7.95).



Process your bonus offer online:
www.zewa.com/offer

Warranty Registration

Visit us online to register your product and receive special offers and news from Zewa.

For a detailed description of your warranty, please refer to the instruction manual.

Register your warranty online:
www.zewa.com



Zewa Inc.
12960 Commerce Lakes Dr. # 29
Fort Myers, FL 33913
Toll Free: 888-993-3592

www.zewa.com